

PRO
SERIES

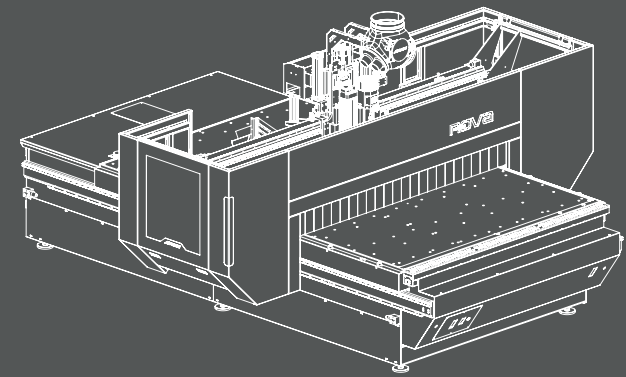

NOVA
SUPER



EN
TR
ES

Making its first overseas investment in the USA as the flagship of the Turkish woodworking machinery industry, AES continues to serve its customers in the North and South America through its center that was launched in Charlotte, North Carolina to provide sales and aftersales services.

Türk ahşap işleme sektörünün bayrak taşıyıcı firması olarak, ABD'de ilk yurt dışı yatırımını yapan AES satış ve satış sonrası hizmetleri için N.Carolina/Charlotte'da aktif hale getirdiği merkezi ile, Kuzey ve Güney Amerika'da hizmet vermeyi sürdürmektedir.

Haciendo su primera inversión en el extranjero en los EE. UU. como el buque insignia de la industria de maquinaria de carpintería turca, AES continúa sirviendo a sus clientes en América del Norte y del Sur a través de su centro que se inauguró en Charlotte, Carolina del Norte para brindar servicios de ventas y posventa.

As part of its policy to expand its sales and aftersales service network on an ongoing basis, AES has incorporated its affiliate AES Europe in Bilzen, Belgium with a view to providing better sales and aftersales services as well as technical support to its customers in Europe

Avrupa kıtasındaki müşterilerine daha iyi satış ve satış sonrası hizmet verebilmek amacıyla Bilzen/Belçika'da AES Europe'u kurdu. AES, müşterilerine teknik destek sağlarken satış ve servis ağını da her geçen gün büyümeye devam etmektedir.

Con el fin de brindar un mejor servicio de venta y posventa a sus clientes en el continente europeo, AES que estableció AES Europe en Bilzen/Bélgica, mientras brinda soporte técnico a sus clientes, continúa expandiendo su red de ventas y servicio día a día.

AES GROUP, which has redefined the sector with the machines and designs it has developed in the Woodworking Machinery sector since the first day it was founded in 1989; it is the flag carrier company of Turkey in the sector. AES, which always continues to be your global partner with its high production capacity, expert staff, global sales and service network, grows with you and continues to develop while growing, with the centers it opened and the service network it established to become one of the world's leading manufacturers in line with its founding vision.

1989 yılında, kurulduğu günden bu yana Ahşap İşleme Makineleri sektöründe geliştirdiği makineler ve tasarımlarla sektörü yeniden tanımlayan AES GROUP; Türkiye'nin sektördeki bayrak taşıyıcı firması konumundadır. Yüksek üretim kapasitesi, uzman kadrosu, küresel satış ve servis ağı ile her zaman global partneriniz olmaya devam eden AES, kuruluş vizyonu doğrultusunda, dünyanın sayılı üreticileri arasında girmek için açtığı merkezler ve kurduğu hizmet ağı ile; sizlerle büyüyor, büyürken de geliştirmeye devam ediyor.

GRUPO AES, que ha redefinido el sector con las máquinas y diseños que ha desarrollado en el sector de la Maquinaria para la Madera desde el primer día de su fundación en 1989; Es la compañía aérea de bandera de Turquía en el sector. AES, que siempre sigue siendo su socio global con su alta capacidad de producción, personal experto, red global de ventas y servicio, crece con usted y continúa desarrollándose mientras crece, con los centros que abrió y la red de servicio que estableció para convertirse en uno de los principales fabricantes del mundo en consonancia con su visión fundacional.

your global partner

AES Group: It grows with you with the goal of becoming a global brand and continues to produce and develop while growing, AES UK continues its Sales and After-Sales Service services in the UK, Ireland, Northern Ireland, Scotland and Wales regions.

AES Group; küresel bir marka olma hedefi ile sizlerle büyümekte, büyürken de üretmeye ve geliştirmeye devam etmektedir. AES UK firması ile Britanya, İrlanda, Kuzey İrlanda, İskoçya ve Galler bölgelerinde Satış ve Satış Sonrası Servis hizmetlerini sürdürmektedir.

Grupo AES; Crece contigo con el objetivo de convertirse en una marca global y continúa produciendo y desarrollándose mientras crece. AES UK continúa con sus servicios de Ventas y Servicio Posventa en las regiones del Reino Unido, Irlanda, Irlanda del Norte, Escocia y Gales.

PRO
SERIES



Produce
for a
Sustainable
Future

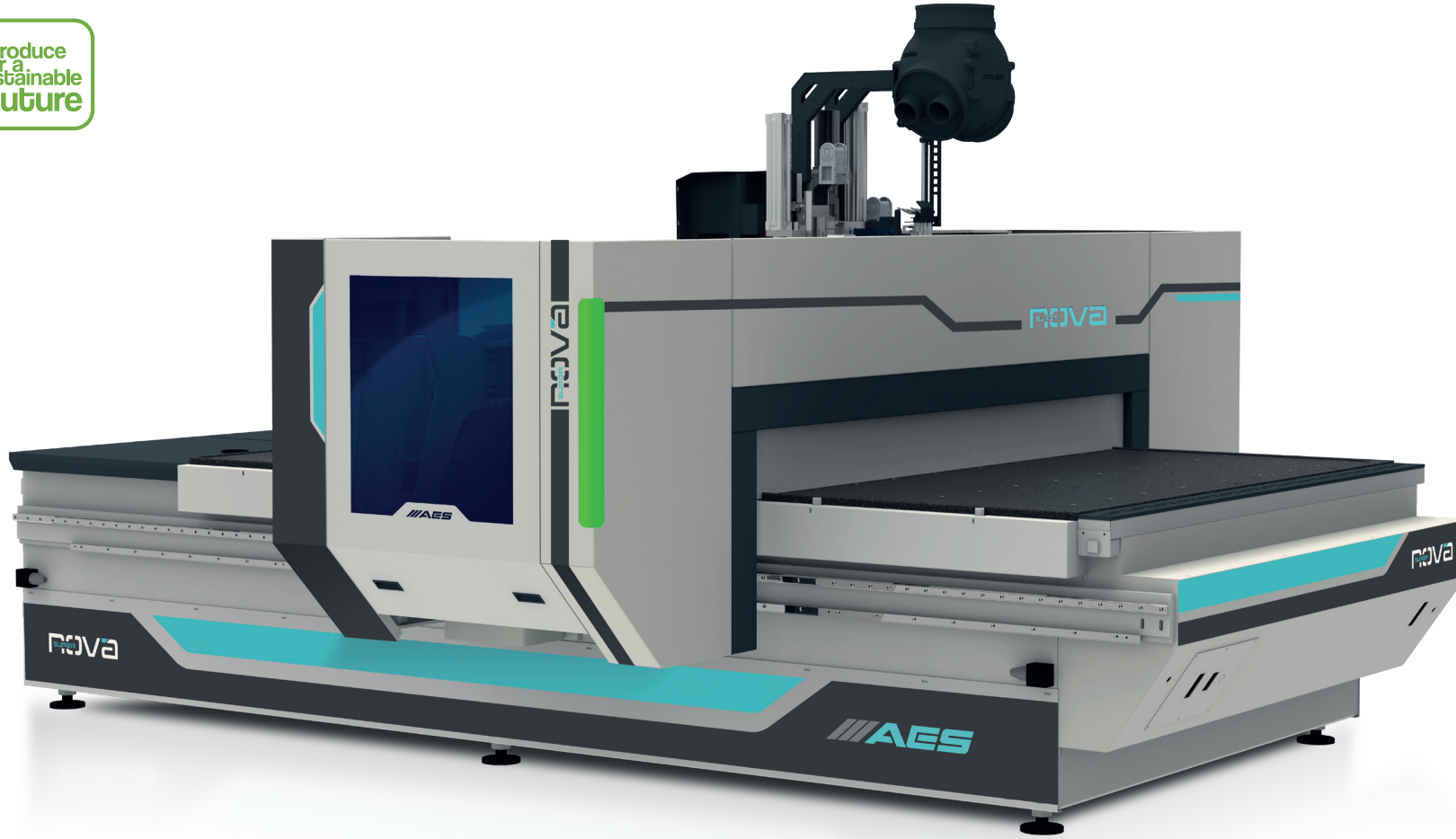

1325
1300x2500mm

1336
1300x3700mm

1632
1600x3200mm

1640
1600x4000mm

2128
2100x 2800mm

2132
2100x 3200mm

2136
2100x 3700mm

2142
2100x 4200mm

Top
quality
professional
solutions

Üstün kalite, profesyonel çözümler
Calidad superior, soluciones profesionales

EN

PRO series machines are our product group that combines fast and precise result with energy saving in your mass production processes PRO Series, which offers economy and professionalism as a whole for developing and changing market conditions, was created by combining quality and performance in the R-D process with a cost-effective strategy taking into account your investment costs in production

TR

PRO serisi makineler, seri üretim işlemlerinizde hızlı ve hassas sonuçları, enerji tasarrufu ile birleştiren ürün grubumuzdur. Gelişen ve değişen piyasa koşulları için ekonomi ile profesyonelliği bir bütün halinde sunan PRO Serisi, üretim süreçrinizde yatırım maliyetlerinizi göz önünde bulundurarak AR&GE sürecinde kalite ve performansın uygun maliyet stratejisi ile birleştirilmesiyle oluşturuldu.

ES

Las máquinas de la serie PRO son nuestro grupo de productos que combina resultados rápidos y precisos con el ahorro de energía en sus procesos de producción en masa. La serie PRO, que ofrece economía y profesionalidad en su conjunto para desarrollar y cambiar las condiciones del mercado, se creó combinando la calidad y el rendimiento en el proceso de I+D con una estrategia rentable que tiene en cuenta sus costos de inversión en producción.herramientas automáticas.

Models
Modeller
Modelo

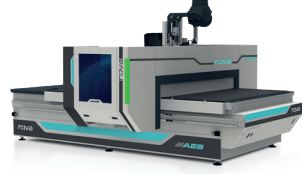

Design Your Next Step

Super Nova is designed for nesting applications. It provides fast and precise cutting for entry-level milling applications. In addition to 3D surface treatment and nesting applications, it is possible to process different types of materials such as plastic, alucobond, aluminum, composite, and etc. With additional options, it can be used in vertical boring applications and door processing applications.

Super Nova nesting uygulamaları için tasarlanmıştır. Giriş seviye freze uygulamaları için hızlı ve hassas kesim yapmaya imkan sağlar. 3D yüzey işleme ve nesting uygulamalarının yanında plastik, alukobond, alüminyum, kompozit vb. farklı tip malzemelerin işlenmesi mümkündür. Ek opsiyonlar ile dik delik işleme uygulamaları ve kapı işleme uygulamalarında kullanılabilir.

Super Nova está diseñado para aplicaciones de anidamiento. Proporciona un corte rápido y preciso para aplicaciones de fresado de nivel básico. Además de las aplicaciones de anidamiento y tratamiento de superficies 3D, es posible procesar diferentes tipos de materiales como plástico, alucobond, aluminio, compuestos, etc. Con opciones adicionales, se puede usar en aplicaciones de perforación vertical y procesamiento de puertas.



Maximum Productivity

Maksimum üretkenlik
Máxima productividad

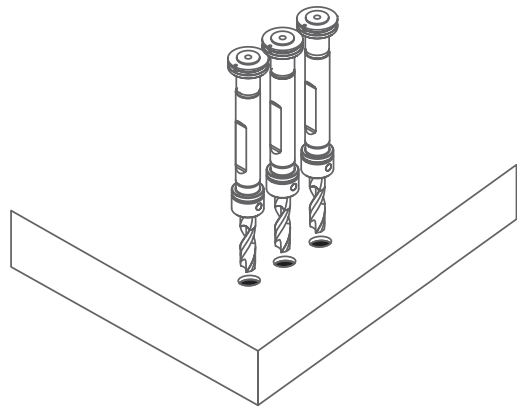

BORING UNIT

ÇOKLU DELİK ÜNİTESİ

UNIDAD DE ORIFICIOS MÚLTIPLES

EN

Shorten your lead time with customized drilling unit options

TR

İhtiyaçlarınıza göre şekillendirilebilen delik ünitesi seçenekleri ile üretim sürecinizi kısaltın.

ES

Acorte su proceso de producción con opciones de unidades de orificios que pueden moldearse según sus necesidades.

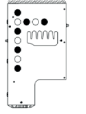
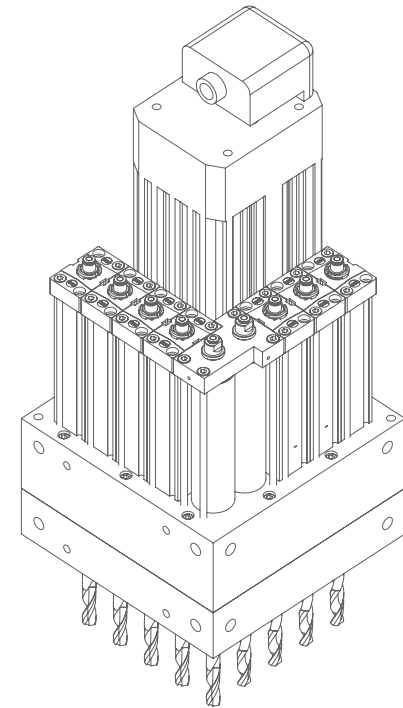

10V

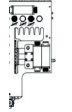

10V - 3x2H - 1 S

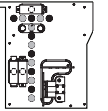

14V - 3x2H - 1 S

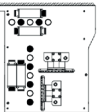

12V - 4x2H - 2 S

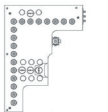

18V

HIGH SPEED & PRECISION

YÜKSEK HIZ - YÜKSEK HASSASİYET

ALTA VELOCIDAD Y ALTA PRECISIÓN

EN

High quality spindle motor ensures the best results with high speed and maximum precision in all machining applications, including 3D.

TR

Yüksek kaliteli spindle motoru, 3D dahil tüm işleme uygulamalarında yüksek hız ve maksimum hassasiyetle en iyi sonuçları almanızı sağlar.

ES

El motor de husillo de alta calidad garantiza los mejores resultados con alta velocidad y máxima precisión en todas las aplicaciones de mecanizado, incluido el 3D.

EXTENDED AGGREGATE USAGE AREA

AGGREGATE İLE GENİŞ KULLANIM ALANI

UNIDAD CAMBIADOR DE HERRAMIENTAS MOVILES

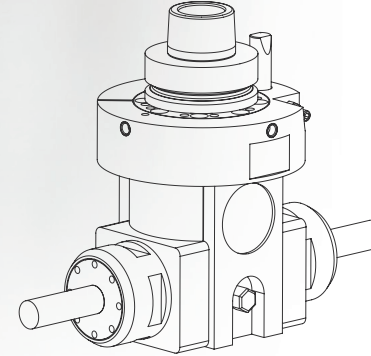

PROFESSIONAL VACUUM EQUIPMENT

PROFESYONEL VAKUM EKİPMANLARI

EQUIPOS DE VACÍO PROFESIONAL

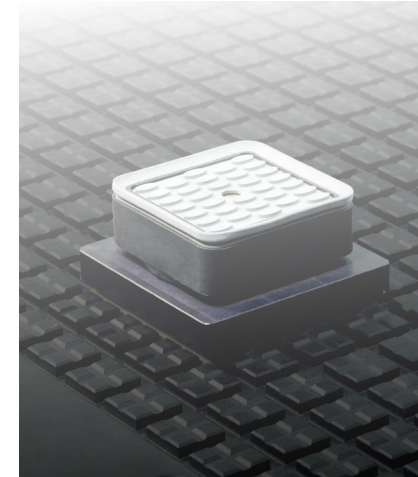

CENTRAL LUBRICATION UNIT

Lubricates the machine at lubrication points manual.

MERKEZİ YAĞLAMA ÜNİTESİ
Yağlama noktalarında makineyi manuel olarak yağlar.

UNIDAD CENTRAL DE LUBRICACIÓN

Lubrica la máquina en los puntos de lubricación manual.



AXIS CONTROL WITH SERVO MOTORS

State of the art motors located on each axis ensure precise acceleration at high speed.

SERVO MOTORLAR İLE EKSEN KONTROLÜ

Tüm eksenlerde bulunan son teknoloji üniteli motorlar, yüksek hızlarda hassas ivmelenme sağlar.

CONTROL DE EJES CON SERVOMOTORES

Los motores de última generación en todos los ejes proporcionan una aceleración precisa a altas velocidades.

HIGH-QUALITY RACK & RAIL

Low-vibration, dynamic & high quality rails and cremayer are used to provide the best results at high speeds.

YÜKSEK KALİTE KREMAVER VE RAY

Yüksek hızlarda en iyi sonuç için düşük titreşim sağlayan dinamik, yüksek kaliteli ray ve kremayerler kullanılmaktadır.

CALIDAD EXCELENTE CARRIL DE CREMALLERA

Inin vibraciones bajas para mejores resultados a altas velocidades. Se utilizan rieles y racks dinámicos y de alta calidad. Estructura corporal.



VACUBOOST

Where the
Spindle
there is
Power

*Spindle nerede güç orada
Donde esta Spindle allí está la potencia*

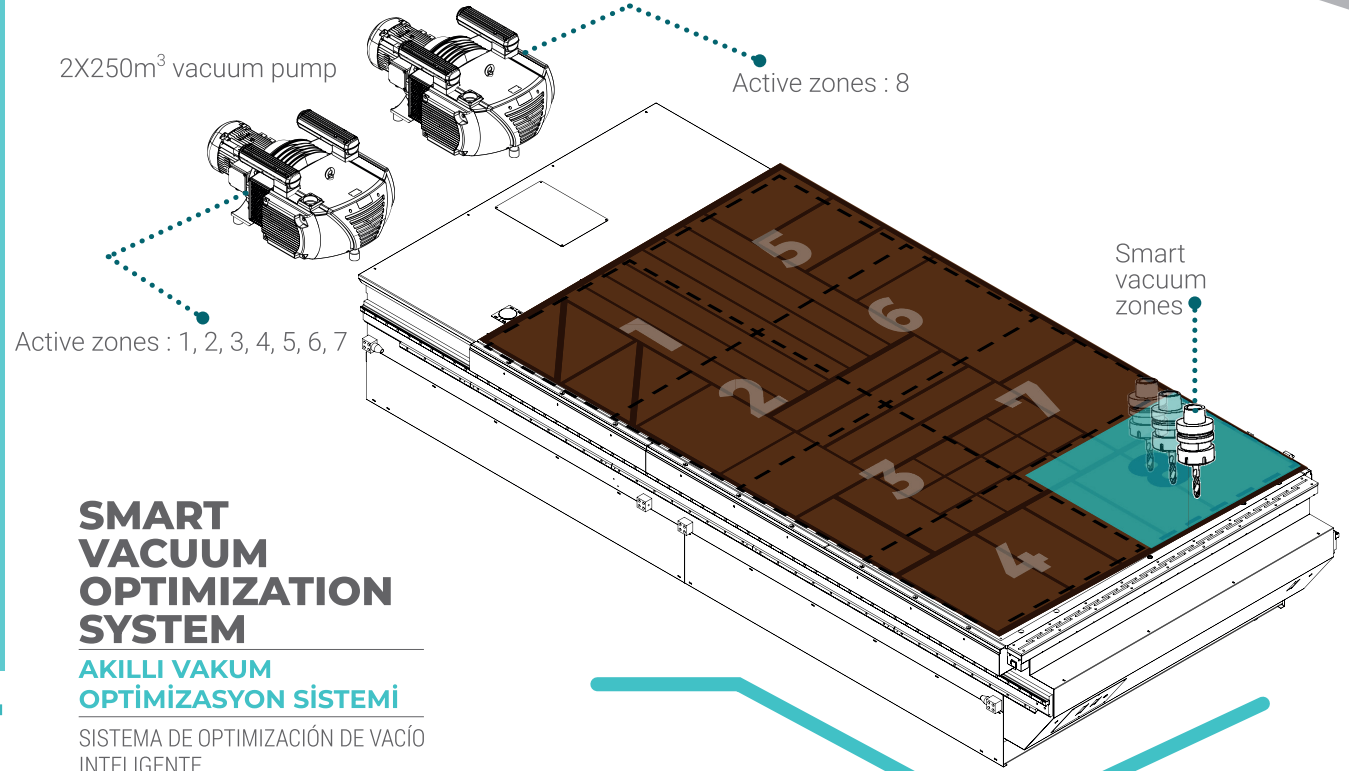

SMART VACUUM OPTIMIZATION SYSTEM

AKILLI VAKUM OPTİMİZASYON SİSTEMİ

SISTEMA DE OPTIMIZACIÓN DE VACÍO INTELIGENTE

EN Our proprietary VACUBOOST technology, focusing on the position of the vacuumed work part for unrivalled gripping power, has been developed to enable you to machine small work parts or porous materials such as chipboards easily.

TR Küçük parçalara veya sunta gibi geçirgen malzemeleri rahatlıkla işleyebilmeniz için geliştirdiğimiz patentli VACUBOOST teknolojisi ile vakumlanan parçanın konumuna odaklanarak benzersiz bir tutuş gücü sağlar.

ES Proporciona un poder de agarre único al centrarse en la posición de la pieza aspirada con la tecnología patentada VACUBOOST que hemos desarrollado para que pueda procesar fácilmente piezas pequeñas o materiales permeables como la madera aglomerada.

HIGH -EFFICIENCY VACUUM PUMP

GÜÇLÜ VAKUM POMPASI

POTENTE BOMBA DE VACÍO

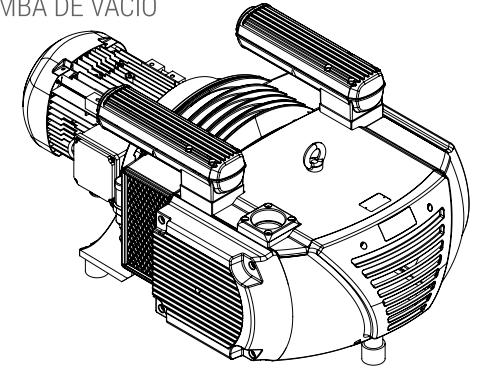

Every Second Counts

Her Saniyeniz Değerli
Cada segundo es valioso

ROTARY MAGAZINE UNIT

HAREKETLİ TAKIM DEĞİŞTİRME ÜNİTESİ

UNIDAD PARA CAMBIAR DE
EQUIPOS MOVIBLE

EN

Quickly change tools with the rotary magazine to shorten machining time

TR

Hareketli takım değiştirme ünitesi ile kolay ve hızlı takım geçişi sağlayarak işleme sürenizi kısaltır.

ES

Reduce el tiempo de procesado al proporcionar un cambio de herramienta fácil y rápido con su unidad de cambio de herramienta móvil.

ES

Mientras que el indicador LED de estado de la máquina muestra el proceso de mecanizado de la máquina, los colores del indicador aumentan la seguridad del operador al siguiente nivel.

EN

While the machine led status indicator shows the machining process of the machine, the colors on the indicator increase operator safety to the next level.

TR

Makine led durum göstergesi makinenin işleme sürecini gösterirken, göstergede bulunan renkler ile operatör güvenliğini üst seviyeye çıkarır

MACHINE LED STATUS

MAKİNE LED GÖSTERGE

ESTADO DEL LED DE LA MÁQUINA



PRO
SERIES



Produce
for a
Sustainable
Future

SUPER
NOVA

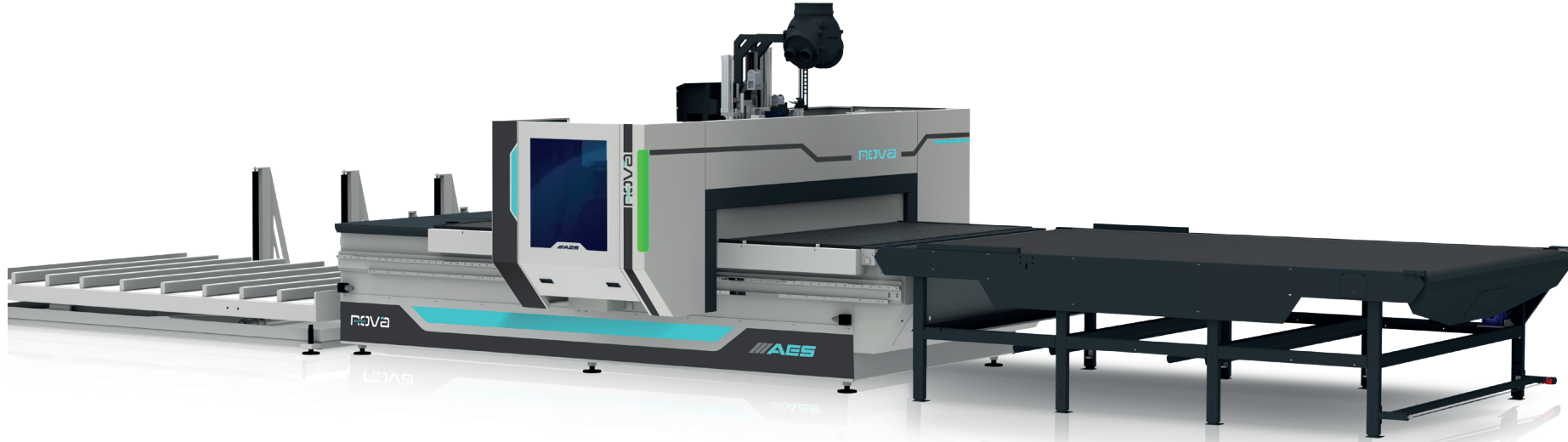
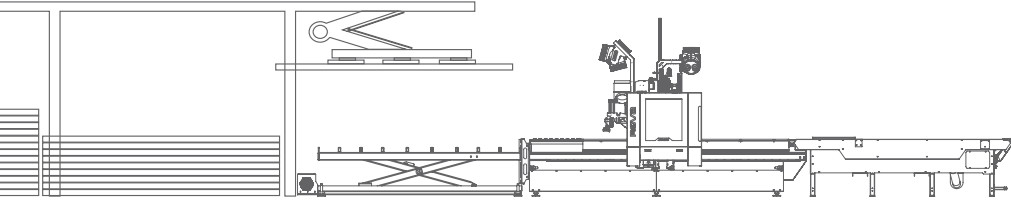

Top
quality
professional
solutions

Üstün kalite, profesyonel çözümler
Calidad superior, soluciones profesionales

EN

PRO series machines are our product group that combines fast and precise result with energy saving in your mass production processes PRO Series, which offers economy and professionalism as a whole for developing and changing market conditions, was created by combining quality and performance in the R-D process with a cost-effective strategy taking into account your investment costs in production

TR

PRO serisi makineler, seri üretim işlemlerinizde hızlı ve hassas sonuçları, enerji tasarrufu ile birleştiren ürün grubumuzdur. Gelişen ve değişen piyasa koşulları için ekonomi ile profesyonelliği bir bütün halinde sunan PRO Serisi, üretim süreçlerinizde yatırım maliyetlerinizi göz önünde bulundurarak AR&GE sürecinde kalite ve performansın uygun maliyet stratejisi ile birleştirilmesiyle oluşturuldu.

ES

Las máquinas de la serie PRO son nuestro grupo de productos que combina resultados rápidos y precisos con el ahorro de energía en sus procesos de producción en masa. La serie PRO, que ofrece economía y profesionalidad en su conjunto para desarrollar y cambiar las condiciones del mercado, se creó combinando la calidad y el rendimiento en el proceso de I+D con una estrategia rentable que tiene en cuenta sus costos de inversión en producción.herramientas automáticas.

1325
1300x2500mm

1336
1300x3700mm

1632
1600x3200mm

1640
1600x4000mm

2128
2100x 2800mm

2132
2100x 3200mm

2136
2100x 3700mm

2142
2100x 4200mm

Models
Modeller
Modelo



Standalone



Semi Automatic Line



Full Automatic Line

Simply Automate Your Business

İşinizi kolayca otomatikleştirin.
Simplesmente automatice su negocio.



LOADING UNIT
YÜKLEME ÜNİTESİ
UNIDAD DE CARGA

02

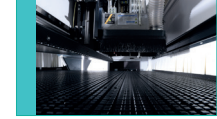

UNLOADING & CLEANING UNIT
BOŞALTIMA & TEMİZLEME ÜNİTESİ
UNIDAD DE DESCARGA Y LIMPIEZA

03

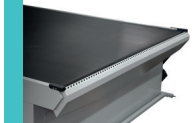

CONVEYOR UNIT
KONVEYÖR ÜNİTESİ
UNIDAD TRANSPORTADORA

04

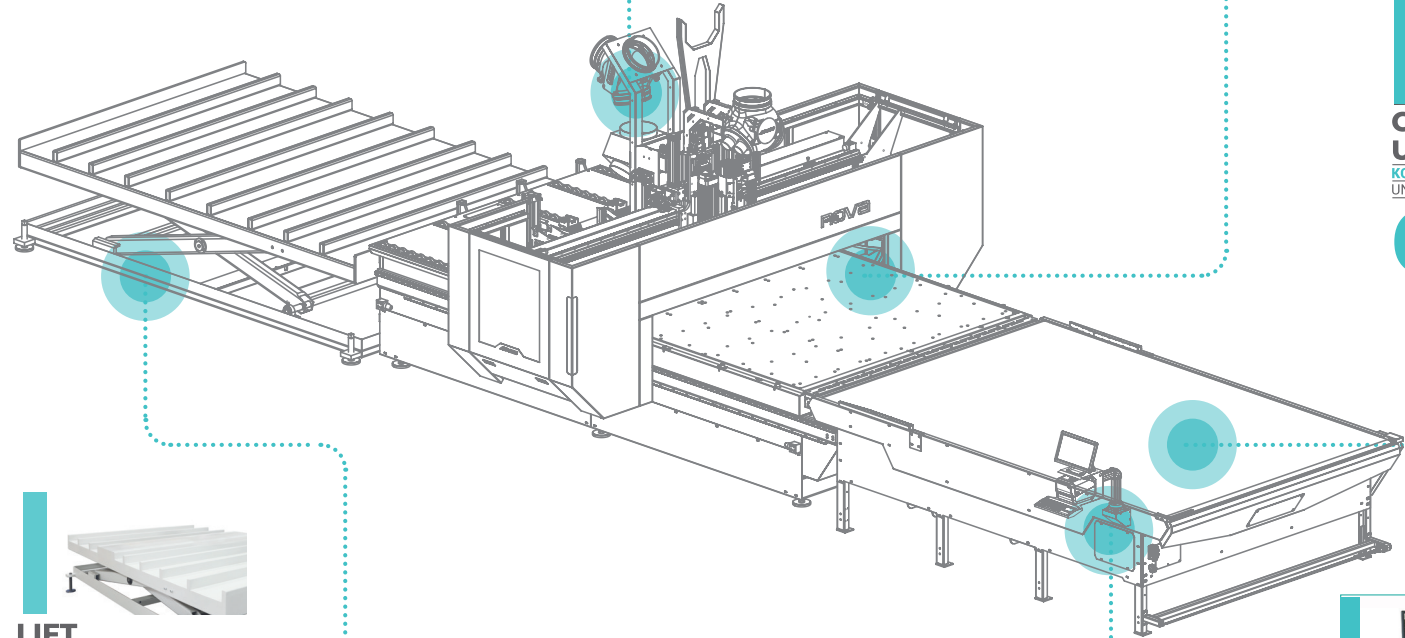

LIFT UNIT
LİFT ÜNİTESİ
UNIDAD DE ELEVACIÓN

01



MANUAL LABELLING SYSTEM
MANUAL ETİKETLEME SİSTEMİ
SISTEMA DE ETIQUETADO MANUAL

05



NEXT GENERATION CNC CONTROL UNIT

YENİ JENERASYON CNC KONTROL ÜNİTESİ

UNIDAD DE CONTROL CNC DE ÚLTIMA GENERACIÓN

EN

The next generation control unit is powered by a PC designed for industrial operations. It allows you to make your transactions quickly and easily without getting stuck.

TR

Endüstriyel işler için üretilen PC'den gücünü alan yeni jenerasyon kontrol ünitesi. İşlemlerinizi takılmadan, hızlı ve kolay gerçekleştirmenizi sağlar.

ES

Unidad de control de nueva generación alimentada por PC fabricada para trabajos industriales. Le permite realizar sus transacciones de forma rápida y sencilla sin quedarse atascado.

EASY TO USE INTERFACE

KULLANIMI KOLAY ARAYÜZ

INTERFAZ FÁCIL DE USO



USER EXPERIENCE / KULLANICI DENEYİMİ / EXPERIENCIA DE USUARIO



"As easy to use as a mobile phone"

"Telefon kullanmak kadar kolay."

"Tan fácil como usar un teléfono"

"The machine helps us to perform machining operations accurately by guiding us with warning messages."

"Uyarılar bizi yönlendirerek, doğru işlem yapmamıza destek oluyor."

"Las alertas nos orientan y nos ayudan a realizar la acción correcta."

Our aftersales support team is always there for you when you need them thanks to the remote control feature of SUPER NOVA.

SUPER NOVA'nın uzaktan kontrol özelliği ile ihtiyac duyduğunuz her an satış sonrası destek ekibimiz yanınızda.

Gracias a la función de control remoto de SUPER NOVA, nuestro equipo de soporte posventa le apoya siempre que lo necesite.



7

LANGUAGE 7 DİL SEÇENEĞİ OPCIONES DE 7 IDIOMAS

TR / EN / AR / RU / ES / FR / NL

MAXIMUM SAFETY

MAKSİMUM GÜVENLİK

MÁXIMA SEGURIDAD

EN

The safety options of SUPER NOVA were designed to prevent unauthorized access to the work area with a view to maximizing safety of life. These safety options which are designed in compliance with the CE norms will minimize the risk of occupational accidents in your manufacturing processes.

TR

SUPER NOVA' nın güvenlik opsiyonları çalışma alanına yetkisiz girişleri engelleyerek maksimum can güvenliği sağlamak için tasarlanmıştır. CE normlarına uygun şekilde hazırlanan güvenlik opsiyonları ile imalat süreçlerinizde iş kazası risklerini minimize eder.

ES

Las opciones de seguridad de SUPER NOVA están diseñadas para brindar la máxima seguridad humana al evitar el acceso no autorizado a la zona de trabajo. Minimiza los riesgos de accidentes laborales en sus procesos de fabricación con opciones de seguridad preparadas de acuerdo con normativa CE

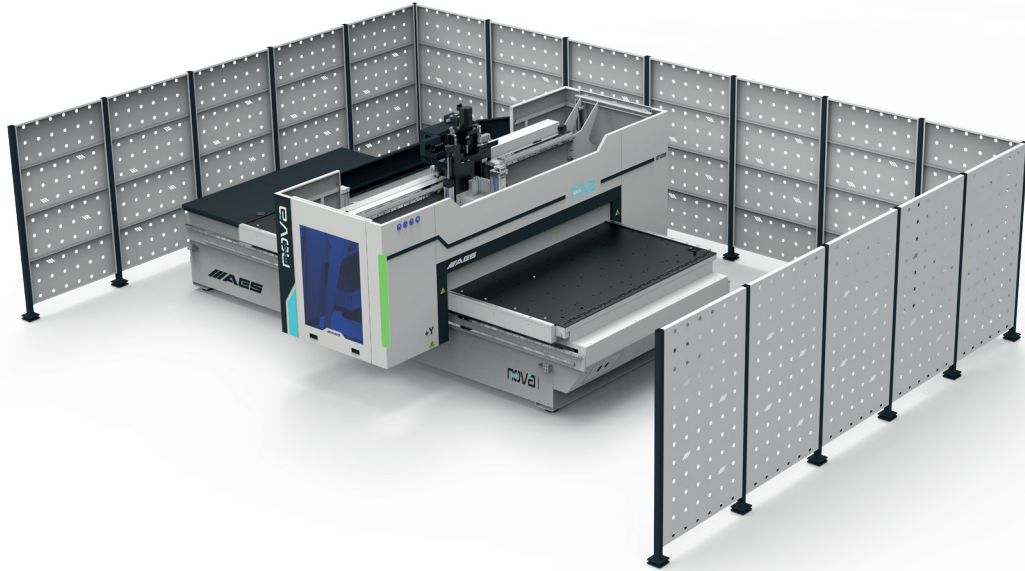

Safety Mats

Güvenlik Paspası
Felpudo de Seguridad

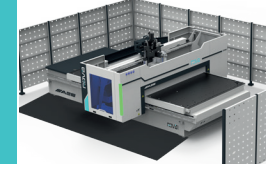

Light Barriers

Işık Bariyeri
Barrera de Luz

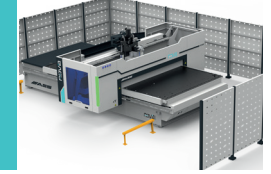

Safety Fences

Güvenlik Çiti
Valla de Seguridad

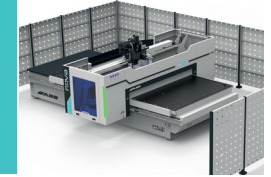

Bumpers

Bumper
Parachoques

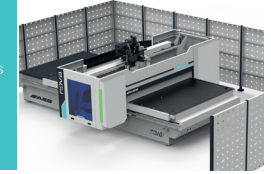

Area Scanning

Alan Tarama
Escaneo de la zona

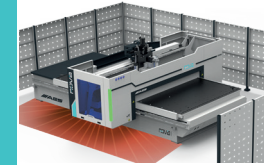

AW

AES WOP

Design freely

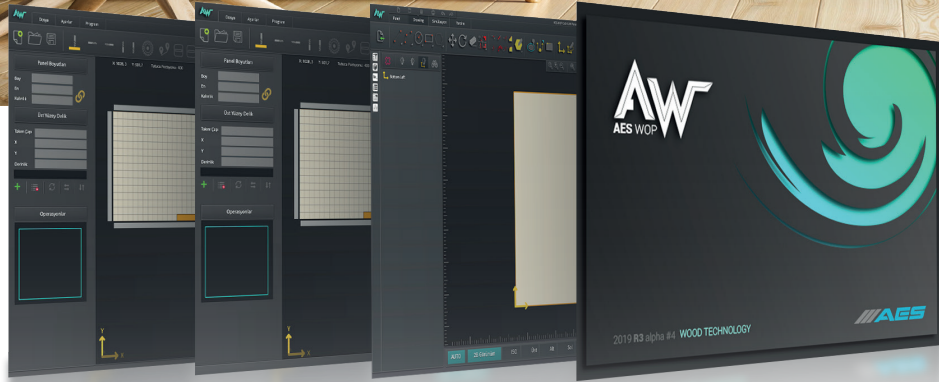

SIMPLY CREATE SMART DESIGNS

BASİTÇE, AKILLI TASARIMLAR OLUŞTURUN

SIMPLEMENTE, CREE DISEÑOS INTELIGENTES

EN

Due to its systemic parametric structure, the design can be changed automatically according to the desired and connection type. Create your designs, save them in the library and customize as needed.

TR

Sistemsel parametrik yapısı sayesinde yapılan tasarımlar istenilen ölçüye ve bağlantı türüne uygun şekilde otomatik olarak değiştirilebilir. Tasarımlarınızı oluşturun ve kütüphaneye kayıtlı edin. İhtiyaç duyduğunuz anda uyarlayın.

ES

Gracias a su estructura paramétrica del sistemática, los diseños se pueden cambiar automáticamente de acuerdo con el tamaño y el tipo de conexión deseados. Cree sus diseños y guárdelos en la biblioteca en el momento que los necesite.



DESIGN
TASARLA
DISEÑO



TRANSFER
TRANSFER ET
TRANSFERIR



PRODUCE
ÜRET
PRODUCCIÓN

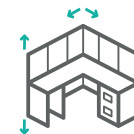
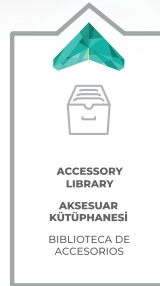
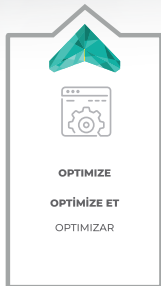
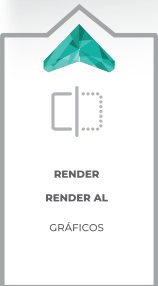

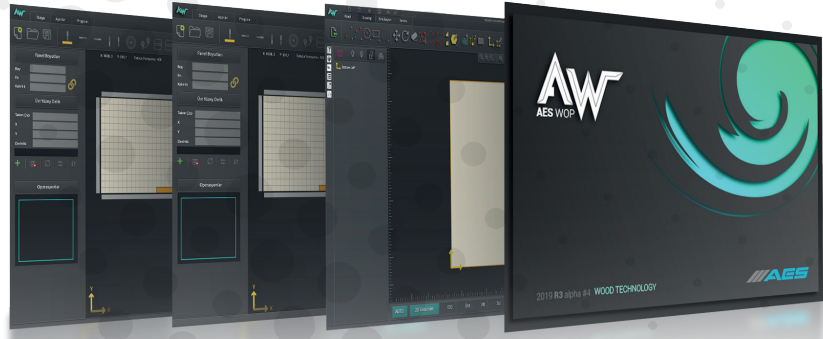

The Fastest way from Design to Manufacturing

TASARIM DAN ÜRETİME EN HIZLI YOL
LA RUTA MÁS RÁPIDA DEL DISEÑO HASTA LA PRODUCCIÓN



EN

AES WOP CAD/CAM program is designed to meet all your design needs. Its easy-to-use interface and advanced features allow you to prepare flexible and fully functional designs. It can be used in a wide range of areas, from design to part position changes, from workpiece definition to 3D simulation, tool path optimization and parametric use. Turn your designs into reality thanks to the software that works fully compatible with the machine.

TR

AES WOP CAD/CAM programı tüm tasarım ihtiyaçlarınızı karşılayacak şekilde tasarlanmıştır. Kullanımı kolay arayüzü ve gelişmiş özellikleri, esnek ve tam işlevsel tasarımlar hazırlamanızı sağlar. Tasarımdan parça pozisyon değişimlerine, çalışma parçası tanımlamadan 3D simülasyon ve takım yolu optimizasyonu ile parametrik kullanıma kadar çok geniş bir alanda kullanılabilir. Makine ile tam uyumlu çalışan yazılım sayesinde tasarımlarınızı gerçeğe dönüştürün.

ES

El programa CAD/CAM AES WOP está diseñado para satisfacer todas sus necesidades de diseño. Su interfaz fácil de usar y sus funciones avanzadas le permiten preparar diseños flexibles y completamente funcionales. Se puede utilizar en una amplia gama de áreas, desde el diseño hasta los cambios de posición de la pieza, desde la definición de la pieza de trabajo hasta la simulación 3D, la optimización de la trayectoria de la herramienta y el uso paramétrico. Convierte tus diseños en realidad gracias al software que funciona totalmente compatible con la máquina.



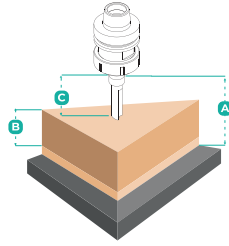

CUTTING HEAD
KESİM YÜKSEKLİĞİ
ALTO DE CORTE

SUPER NOVA

	A	B	C
mm / inch	395 / 15.5	200 / 7.87	170 / 6.69

TECHNICAL INFORMATION TEKNİK ÖZELLİKLER ESPECIFICACIONES TÉCNICAS

SUPER NOVA

	1325	1336	1632	1640	2128	2132	2136	2142
Working Area Dimensions Çalışma Alanı Ölçüleri Mediciones del Area de Trabajo	1300x2500 mm 51x98"	1300x3700 mm 51x145"	1600x3200 mm 63x126"	1600x4000 mm 63x157"	2100x2800 mm 83x110"	2100x3200 mm 83x126"	2100x3700 mm 83x146"	2100x4200 mm 83x165"
Z Axis Distance Z Eksen Ölçüleri Z-As Abstand	200 mm 7.87"							
Axis Speed Eksen Hızları Las Velocidades del eje	70-70-20 m/min 3149-3149-787 IPM							
Spindle Motor Power Spindle Motor Gücü Spilmotorvermogen	9 kW ISO 30 12HP ISO 30							
Boring Unit Çoklu Delik Ünitesi Unidad de Agujeros Múltiples	9 V (Std.)							
Rotary Magazin Unit Rotary Magazin Ünitesi Unidad de Herramientas	8 Pcs 8 Adet							
CAD/CAM Program CAD/CAM Program Programa CAD/CAM	AES WOP							
Vacuum Zone Vakum Bölgesi Zona de Vacío	2	4			6		8	10
Vacuum Pump Power Vakum Pompası Gücü Potencia de la bomba de vacío	140 m³/h 5.4 HP	250 m³/h 8.9 HP	140 m³/h 5.4 HP		250 m³/h 8.9 HP			250 m³/h 8.9 HP
Lift&Loading Unit Lift ve Yükleme Ünitesi Unidad de Elevación y Carga				✓				
Unloading&Cleaning Unit Boşaltma ve Temizleme Ünitesi Unidad de Descarga y Limpieza				✓				
Conveyor Unit Konveyör Ünitesi Unidad de Cinta Transportadora				✓				

TECHNICAL INFORMATION

TEKNİK ÖZELLİKLER

ESPECIFICACIONES TÉCNICAS

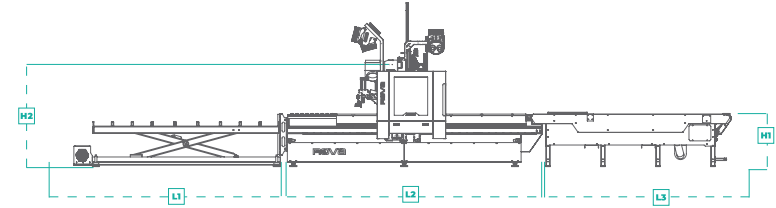
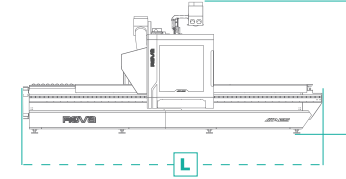
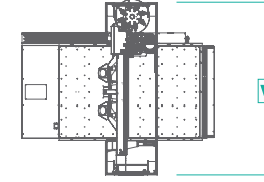

DIMENSIONS ÖLÇÜLER DIMENSIONES	L	W	H
SUPER NOVA 1325	mm / inch	3670 / 144.49	3080 / 121.26
SUPER NOVA 1336	mm / inch	4870 / 191.72	3080 / 121.26
SUPER NOVA 1632	mm / inch	4370 / 172.05	3380 / 133.07
SUPER NOVA 1640	mm / inch	5170 / 203.54	3380 / 133.07
SUPER NOVA 2128	mm / inch	3970 / 156.30	3880 / 152.76
SUPER NOVA 2132	mm / inch	4370 / 172.05	3880 / 152.76
SUPER NOVA 2136	mm / inch	4870 / 191.73	3880 / 152.76
SUPER NOVA 2142	mm / inch	5370 / 211.42	3880 / 152.76

DIMENSIONS ÖLÇÜLER DIMENSIONES	L	L1	L2	L3	W	H1	H2
SUPER NOVA 1325	mm / inch	9410 / 370.47	3005 / 118.31	3670 / 144.49	2375 / 107.68	3080 / 121.26	
SUPER NOVA 1336	mm / inch	13010 / 512.20	4205 / 165.55	4870 / 191.73	3935 / 154.92		
SUPER NOVA 1632	mm / inch	11510 / 453.15	3705 / 145.87	4370 / 172.05	3435 / 135.24	3380 / 133.07	
SUPER NOVA 1640	mm / inch	13910 / 547.64	4505 / 177.36	5170 / 203.54	4235 / 166.73	1130 / 44.49	2540 / 100
SUPER NOVA 2128	mm / inch	10310 / 405.91	3305 / 130.12	3970 / 156.30	3035 / 119.49		
SUPER NOVA 2132	mm / inch	11510 / 453.15	3705 / 145.87	4370 / 172.05	3435 / 135.24	3880 / 152.76	
SUPER NOVA 2136	mm / inch	13010 / 512.20	4205 / 165.55	4870 / 191.73	3935 / 154.92		
SUPER NOVA 2142	mm / inch	14510 / 571.26	4705 / 185.24	5370 / 211.42	4435 / 174.61		

* The technical specifications and drawings provided in the catalogue are non-binding. Stock images and drawings may contain optional equipment. AES Group reserves the right to make amendments without notice.

* Katalogda bulunan teknik özellikler ve çizimler bağlayıcı değildir. Bazı fotoğraflar ve çizimler opsiyonel ekipmanları içerebilir. AES Group bilgilendirme yapmaksızın değişiklik yapma hakkını saklı tutmaktadır.

* Las especificaciones técnicas y dibujos del catálogo no son vinculantes. Algunas fotos y dibujos pueden incluir equipamientos opcionales. Grupo AES se reserva el derecho de realizar cambios sin previo aviso.

ALWAYS WITH YOU

DAİMA YANINIZDA

SIEMPRE CON USTED

EN

Our expert after-sales service staff is 24/7 at your service for all your needs. For your permanent satisfaction, it provides an accurate diagnosis and intervention to all your problems as soon as possible with both instant remote connection support and on-site service. AES GROUP protects your investments with after-sales services for uninterrupted production.



REMOTE AND ON-SITE SERVICE SERVICES

UZAKTAN VE YERİNDE SERVİS HİZMETLERİ

SERVICIOS DE MANDO A DISTANCIA Y LUGAR



TRAINING AND INSTALLATION SERVICES

EĞİTİM VE KURULUM HİZMETLERİ

SERVICIOS DE FORMACIÓN E INSTALACIÓN



SPARE PARTS AND SALES SUPPORT

YEDEK PARÇA VE SATIŞ DESTEĞİ

PIEZAS DE RECAMBIO Y SOPORTE DE VENTA



UNINTERRUPTED CONNECTION WITH WEB PLATFORM

WEB PLATFORMU İLE KESİNTİSİZ BAĞLANTI

CONEXIÓN PERMANENTE CON LAS PLATAFORMA WEB

TR

Uzman satış sonrası hizmet kadromuz, tüm ihtiyaçlarınız için 7 gün 24 saat hizmetinizdedir. Daimi memnuniyetiniz için, gerek anlık uzak bağlantı desteği ile gerekse de yerinde servis hizmeti ile en kısa sürede, tüm sorunlarınıza doğru teşhis sağlayarak müdahale sağlamaktadır. AES GROUP, kesintisiz üretim yapmanız için sunduğu satış sonrası hizmetler ile yatırımlarınızı korur.

ES

Nuestro experto personal de servicio posventa está a su servicio las 24 horas del día, los 7 días de la semana para todas sus necesidades. Para su satisfacción permanente, brinda un diagnóstico preciso e intervención a todos sus problemas a la mayor brevedad posible con soporte instantáneo de conexión remota y servicio en el sitio. GRUPO AES protege sus inversiones con servicios postventa para una producción ininterrumpida.



24/7 0850 22 77 AES
CALL CENTER
CENTRO DE LLAMADAS

CNC MACHINING CENTER (FLAT TABLE GROUP)

CNC İŞLEME MERKEZİ (DÜZ TABLA GRUBU)

CENTRO DE PROCESAMIENTO CNC (GRUPO DE PLATAFORMA PLANA)

ULTRA
SERIES U



▪ RAPTOR ULTRA



▪ EXTREME ULTRA

PRO
SERIES P

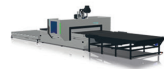

▪ SUPER NOVA



▪ FLEXA PRO

CNC MACHINING CENTER (CONSOLE TABLE GROUP)

CNC İŞLEME MERKEZİ (KONSOL TABLA GRUBU)

CENTRO DE PROCESAMIENTO CNC (GRUPO DE PLATAFORMA DE CONSOLAS)

ULTRA
SERIES U



▪ VEGA ULTRA 5X



▪ VEGA ULTRA

PRO
SERIES P



▪ VEGA 5X PRO

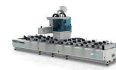

▪ VEGA PRO

CNC DRILLING MACHINES

CNC DELİK MAKİNELERİ

MÁQUINAS DE AGUJERO CNC

ULTRA
SERIES U



▪ GO! ULTRA

PRO
SERIES P



▪ GO! 1300
▪ GO! 1300 M/S
▪ GO! 1300 M/S ATC



▪ SIRIUS 950
▪ SIRIUS 950 M/S
▪ SIRIUS 950 M/S ATC

BEAM SAW MACHINES

PANEL EBATLAMA MAKİNELERİ

SECCIONADORAS

ULTRA
SERIES U



▪ ALPHA PS 05
▪ ALPHA PS 06



▪ ALPHA PS 03
▪ ALPHA PS 04

PRO
SERIES P



▪ BETA PS 03
▪ BETA PS 04

EDGE BANDING MACHINES

KENAR BANTLAMA MAKİNELERİ

CANTEODORAS MONOLATERALES AUTOMÁTICAS

ULTRA
SERIES U

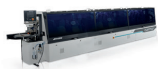

▪ GAMMA ULTRA

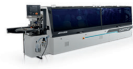

▪ GAMMA MX

PRO
SERIES P

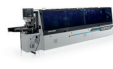

▪ PRIMA 6M
▪ PRIMA 5M

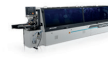

▪ GAMMA 7M
▪ GAMMA 6M

PRODUCTS GROUP

ÜRÜN GRUPLARIMIZ

GRUPO DE PRODUCTOS

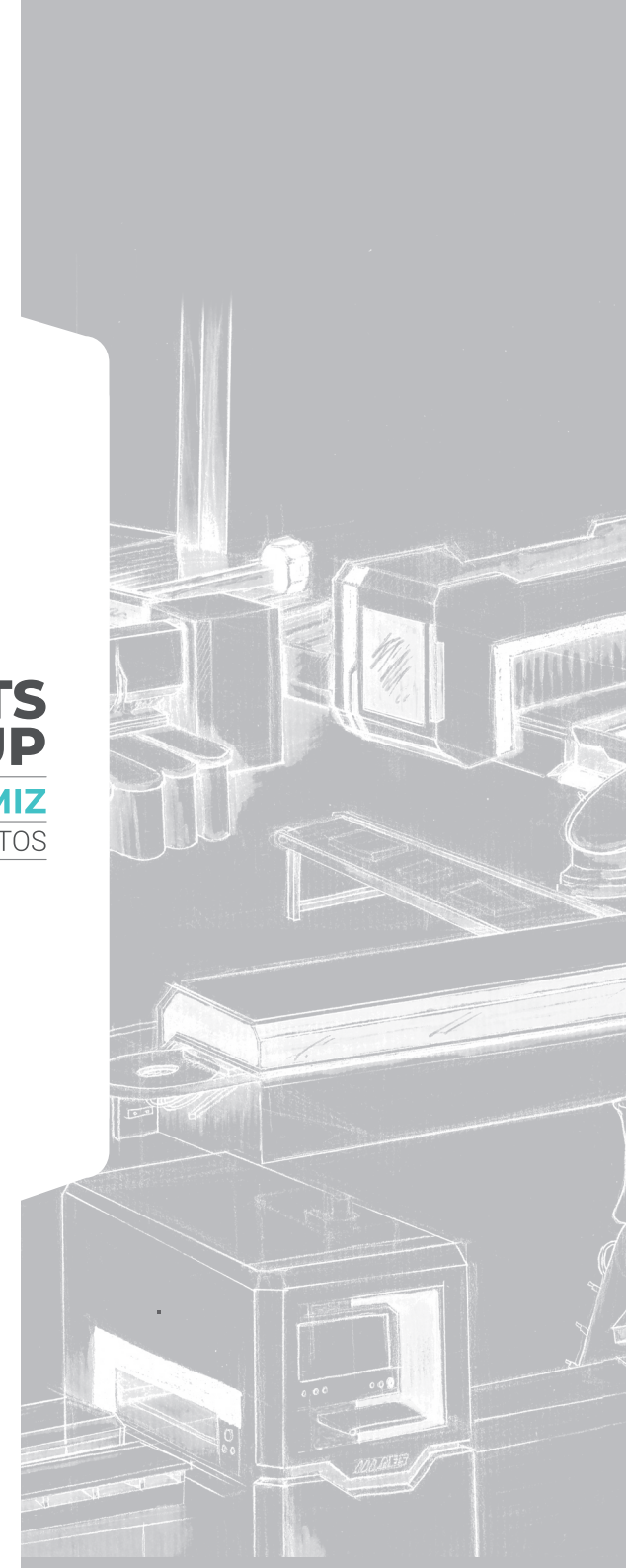

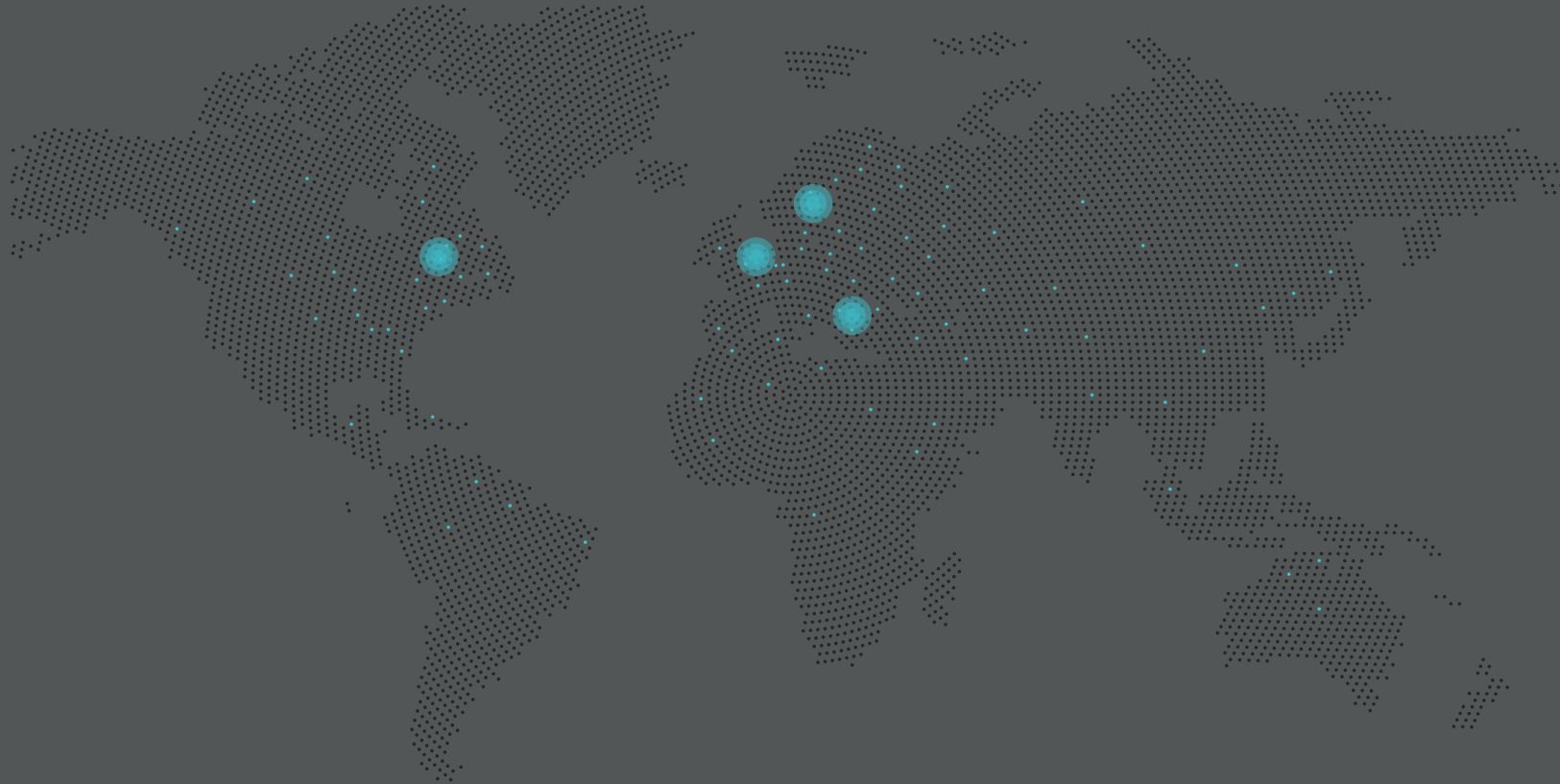

AES HEADQUARTER

NOSAB Şeftali Cd.
118. Sk. No:4 Nilüfer
16140 Bursa / TÜRKİYE

Tel : +90 224 443 33 90
Fax : +90 224 443 29 65

info@aesgroup.com.tr
www.aesgroup.com.tr



AES EUROPE BVBA

Kruisbosstraat
2b2-6186, 3740
Bilzen / BELGIUM

Tel : +32 89 81 1505
Fax : +32 89 81 1505

info@aesgroupeurope.com
www.aesgroupeurope.com



AES AMERICA INC.

4508-B Westinghouse
Blvd.Charlotte, 28273
NC USA

Tel : +1 704 817 7037
Fax : +1 704 817 7036

info@aesgroupamerica.com
www.aesgroupamerica.com



AES GROUP MACHINERY UK LTD

Unit 6, Dakota Business Park, Dakota
Way, Burscough, Lancashire L40 8AF
UNITED KINGDOM

Tel : +44 800 083 8844
Fax : +44 800 083 8855

info@aesgroupukmachinery.co.uk
www.aesgroupukmachinery.co.uk



www.aesgroup.com.tr